

(K) Competitors: Safety

Reference should be made to the appropriate sections in the specific regulations as to which of the following are mandatory or recommended for any particular branch of motorsport.

Roll-Over Protection Systems

Introduction

1. The following are various specifications and configurations that can be used in manufacturing, preparing and installing Roll-Over Protection Systems (ROPS) into Production Cars, Touring Cars Saloon and Sports Cars (1.6.1), Sports Racing Cars (1.6.2), Single Seaters (1.6.3), and other forms of Competition Vehicles (1.6.4). The details covered in this section give many permutations, the Motorsport UK mandatory requirements are the minimum acceptable. Care should be taken to check FIA International requirements for Groups, Classes and Formulae which may not be covered by this section, which is for Motorsport UK National and lower status events.

Definitions

1.1.1.1. Safety Cage. A structural framework designed to prevent serious bodyshell deformation in the case of a collision or a car turning over.

1.1.1.2. Rollbar. Structural frame or hoop and mounting points.

1.1.1.3. Rollcage. Structural framework made up of a main rollbar and a front rollbar (or two lateral rollbars), their connecting members, one diagonal member, backstays and mounting points (see drawings K5 and K6).

1.1.1.4. Main Rollbar. Structure consisting of a near-vertical frame or hoop located across the vehicle just behind the front seats.

1.1.1.5. Front Rollbar. Similar to main rollbar but its shape follows the windscreen pillars and top screen edge.

1.1.1.6. Lateral Rollbar. Structure consisting of a near-vertical frame or hoop located along the right or left hand side of the vehicle. The rear legs of a lateral rollbar must be just behind the front seats. The front leg must be against the screen pillar and dashboard such that it does not unduly impede entry or exit of driver or co-driver.

1.1.1.7. Longitudinal Member. Longitudinal tube which is not a part of the main, front or lateral rollbar, for example, a backstay.

1.1.1.8. Diagonal Member. Transverse tube between a top corner of the main rollbar or upper end of a backstay and a lower mounting point on the opposite side of the rollbar or backstay.

1.1.9. Framework Reinforcement. Reinforcing member fixed to the rollcage to improve its structural efficiency.

1.1.10. Reinforcement Plate. Metal plate fixed to the bodyshell or chassis structure under a rollbar mounting foot to spread load into the structure.

1.1.11. Mounting Foot. Plate welded to a rollbar tube to permit its bolting or welding to the bodyshell or chassis structure, usually onto a reinforcement plate.

1.1.12. Removable Members. Structural members of a safety cage which are able to be removed.

1.1.13. Harness Bar. A transverse tubular member attached across either the main hoop or backstays to accept harness mountings.

Specifications

1.2.1. ROPS must be designed and made so that, when correctly installed, they substantially reduce the risk of injury to the occupants. The essential features of an efficient ROPS are that it is designed to suit the particular vehicle, is of sound construction, has adequate mountings and is a close fit to the bodyshell.

1.2.2. The ROPS must not unduly impede Driver and Co-Driver access to the vehicle. Members may intrude into the interior space by passing through the dashboard, front side trim, rear side trim, and rear seats which may be folded down. ROPS must not extend beyond the front upper or rear suspension mounting points of the vehicle, with the exception of backstays which may extend beyond the rear suspension mounting points if necessary to achieve the required 30° angle. Any modification to a homologated ROPS (other than fitment of Roof Reinforcement, Windscreen Pillar Reinforcement, Doorbars and Harness Bars) is prohibited. Tubes must not carry any liquids or gases, other than air at atmospheric pressure, or any other item.

1.2.3. Compulsory Diagonal Member. Different ways of fitting the compulsory diagonal member (see drawings K5 and K6). The combination of several members is permitted.

1.2.4. Optional Reinforcing Members. Each type of reinforcement (see drawings K7 to K12) may be used separately or combined with others.

Note: Throughout these sections an asterisk(*) indicates a requirement for additional information to be printed in the Supplementary Regulations (SRs). Text shown in *Italics* indicate a Regulation which may be amended in the SRs. Text shown in red indicates a new or amended regulation for 2024.

What's holding you back?

FIA APPROVED **SAFETY HARNESS RANGE** BY THE CHAMPIONS OF SAFETY

With the sole focus on driver safety, comfort and ease of use, Lifeline harnesses are homologated to meet the FIA 8853-2016 standard and backed up by Lifeline's commitment to innovation, attention to detail and quality.



STYLE: BECKETTS

Our entry level harness range available in either 2" or 3" webbing on the shoulder straps. FHR compatible.

Colours: **Black, Blue**



STYLE: COPSE

Our state of the art harness features aluminium adjusters for quick, precise easy adjustment and release. FHR only.

Colours: **Black, Blue**

Incorporating the finest materials and available in three styles and colours - black, blue and red - to suit clubman and professional drivers in Sports Cars, Single Seaters, Touring, GT and Rally.



UNIQUE BUCKLE MECHANISM

Designed for easy, positive latching, the lightweight buckle is manufactured from high quality aerospace grade materials, promoting maximum driver confidence.



Check out our **Overview** and **Safety** videos on the website homepage www.lifeline-fire.co.uk

DESIGNED AND MADE IN COVENTRY, UK

Champions of Safety
www.lifeline-fire.co.uk

30
YEARS
1974-2024

Lifeline

Fire & Safety Systems Ltd.

LIFELINE FIRE & SAFETY SYSTEMS LTD | Coventry CV4 8AU | Telephone: +44 (0)24 7671 2999

Technical Specifications

1.3.1. Main, Front and Lateral Rollbars. These frames or hoops must be made in one piece without joints. Their construction must be smooth and even, without ripples or cracks. The vertical part of the main rollbar must be as straight as possible and as close as possible to the interior contour of the bodyshell. The front leg of the front rollbar or a lateral rollbar must be straight, or if it is not possible, must follow the windscreen pillars and have only one bend unless a windscreen pillar reinforcement [1.3.5(e)] is fitted.

The mounting foot must not be rearward of the foremost point of the rollbar.

Where the main rollbar forms the rear legs of a lateral rollbar (see drawing K6), the connection to the lateral rollbar must be at roof level. To achieve an efficient mounting to the bodyshell, the original interior trim may be modified around the safety cage and its mountings by cutting it away or by distortion. However, this modification does not permit the removal of the complete parts of upholstery or trim. Where necessary, the fusebox may be relocated to enable a rollcage to be fitted.

1.3.2. Mounting of ROPS to the Bodyshell.

Minimum mountings are:

- 1 for each leg of the main or lateral rollbar.
- 1 for each leg of the front rollbar.
- 1 for each backstay (see 1.3.3).

Each leg of a main, lateral or front rollbar must be attached, via a mounting foot, by at least three bolts, minimum M8 ISO grade 8.8 and utilising a steel reinforcement plate of a material of at least the same thickness as the wall of the tube to which it is being welded (minimum 3mm) and of at least 120cm² area which is welded to the bodyshell (see drawings K13 to K18). The mounting foot or leg may alternatively be welded directly to the bodyshell/reinforcement plate in accordance with drawing K13.

1.3.3. Backstays. These are compulsory and must be attached near the roofline and near the top outer bends of the main rollbar on both sides of the car. They must make an angle of at least 30° with the vertical, must run rearwards and be straight and as close as possible to the interior side panels of the bodyshell. Their materials specification, diameter and thickness must be as defined in 1.4.1. Forward facing stays are permitted if an angle of 30° cannot be achieved with Backstays, providing they do not unduly impede Driver and Co-Driver access to the vehicle.

Their mountings must be reinforced by plates. Each backstay must be secured by bolts having a cumulative section area at least two thirds of that recommended for each rollbar leg mounting in 1.3.2 above, and with identical reinforcement plates of a least 60cm² area (see drawing K13). A single bolt in double shear is permitted, providing it is of adequate section and strength (see drawing K20) and provided that a bush is welded into the backstay.

The mounting foot or backstay may alternatively be welded directly to the bodyshell/reinforcement plate in accordance with drawing K13.

1.3.4. Diagonal Members. At least one diagonal member must be fitted. Their location must be in accordance with drawings K5 or K6 and they must be straight. The combination of several diagonal members is permitted.

Where two diagonals in the form of a cross are used, at least one of the diagonals must be a single piece tube.

The attachment points of the diagonal members must be so located that they cannot cause injuries. They may be made removable but must be in place during events. The lower end of the diagonal must join the main rollbar or back-stay not further than 100mm from the mounting foot. The upper end must join the main rollbar not further than 100mm from the junction of the backstay joint, or the backstay not more than 100mm from its junction with the main rollbar.

They must comply with the minimum specification set out in 1.4.1. A diagonal member fixed to the bodyshell must have reinforcement plates as defined in 1.3.3.

1.3.5. Optional Reinforcement of ROPS. The diameter, thickness and material of reinforcements must be as defined in 1.4.1. They must be either welded in position or installed by means of demountable joints. Reinforcement tubes must not be attached to the bodyshell.

(a) Transverse Reinforcing Members:

The fitting of two transverse members as shown in drawing K9 is permitted. The transverse member fixed to the front rollbar must not encroach upon the space reserved for the driver or co-driver. It must be placed as high as possible but its lower edge must not be higher than the top of the dashboard.

(b) Doorbars (for side protection):

Longitudinal members must be fitted at each side of the vehicle (see drawings K9 and K12). They may be removable.

The side protection must be as high as possible but not higher than one half of the total height of the door aperture measured from its base.

Where two members in the form of a cross are used, at least one of the members must be a single piece tube.

Where configuration 12(j) is used a reinforcing gusset must connect the tubes along the horizontal length.

(c) Roof Reinforcement:

Reinforcing the upper part of the rollcage by adding members as shown in drawing K10 is permitted.

(d) Reinforcement of bends and junctions:

The reinforcement of the junction between the main rollbar or the front rollbar and the longitudinal members is permitted as shown in drawing K12 as is the reinforcement of the top rear bends of the lateral rollbars.

The ends of these reinforcing tubes must not be more than half way down or along the members to which they are attached.

(e) Windscreen Pillar Reinforcement:

A tube the upper end of which must be less than 100mm from the junction between the front (lateral) rollbar and the longitudinal (transversal) member and the lower end less than 100mm from the front mounting foot of the front (lateral) rollbar, as shown in drawing K62.

The tube may be bent on condition that it is straight in side view and that the angle of the bend does not exceed 20°.

1.3.6. Protective Padding. Where the driver's or co-driver's bodies or crash helmets could come into contact with the ROPS, non-flammable padding should be provided for protection (1.6.6).

**Safety
Devices®**



50 YEARS OF ROLL OVER PROTECTION

Roll Cages | FIA/MSUK Homologated designs | 2500+ modern and historic solutions
Tier 1 OEM Supplier | Engineering Design Services | In-House Laser Scanning



arkonik.com



AUTOMOTIVE | MOTORSPORT | 4x4 | MILITARY | FLEET | EXPEDITION | EMERGENCY SERVICES

Safety Devices International Ltd

Cambridge House | Holborn Avenue | Mildenhall | Suffolk, IP28 7AN

+44 (0) 1638 713 606 ✉ motorsport@safetydevices.com 🌐 www.safetydevices.com
f @SafetyDevicesIntl 📷 @SafetyDevices in safetydevices 📺 SafetyDevicesLtd

1.3.7. Removable Members. Should removable members be used in the construction of a ROPS, the demountable joints used must comply with an approved type (see drawings K21 to K30). The screws and bolts must be of adequate diameter and of ISO Standard 8.8 or better. FIA homologated demountable joints are also permitted.

Demountable joints must not be used as part of a main, front or lateral rollbar because they act as hinges in the principal structure and allow deformation. Their use is solely for attaching members to the rollbars and for attaching a lateral rollbar to a main rollbar (see drawing K2). In this last case, hinged joints in drawings K21 to K30 must not be used.

1.3.8. Guidance on Welding. All welding should be of the highest possible quality with full penetration and preferably using a gas shielded arc. Although good external appearance of a weld does not necessarily guarantee its quality, poor looking welds are never a sign of good workmanship. When using heat-treated steel the instructions of the manufacturer must be followed (special electrodes, gas protected welding). It is to be emphasised that the use of heat-treated or medium carbon steels may cause problems and that bad fabrication may result in a decrease in strength (caused by brittle heat-affected zones) or inadequate ductility.

1.3.9. Harness Bars. Minimum dimensions 38mm x 2.5mm or 40mm x 2.0mm. Cold Drawn Seamless Carbon Steel with minimum tensile strength of 350N/mm². Harness straps may be attached by looping around the tube or by threaded fixings using inserts as drawing No. 44 welded into the tubes(s).

Material Specifications

1.4.1. Specifications of the tubes used:

Material

Cold Drawn Seamless Unalloyed Carbon Steel, containing a maximum of 0.3% of carbon.

Note: For an unalloyed carbon steel the maximum content of additives is 1.7% for manganese and 0.6% for other elements.

Minimum Yield Strength

350 N/mm²

Minimum Dimensions (Ø in mm)

- (a) Mandatory tubular members
45 x 2.5 (1.75" x 0.095") or 50 x 2.0 (2.0" x 0.083").
38 x 2.5 (1.5" x 0.095") or 40 x 2.0 (1.6" x 0.083").
(For roll cages/bars approved prior to 1.1.95).
- (b) Optional tubular members
38 x 2.5 (1.5" x 0.095") or 40 x 2.0 (1.6" x 0.083").

1.4.2. In selecting the steel, attention must be paid to obtaining good elongation properties and adequate weldability.

1.4.3. The tubing must be bent by a cold working process and the centreline bend radius must be at least three times the tube diameter. If the tubing is ovalised during bending, the ratio of minor to major diameter must be 0.9 or greater.

Exceptions

The only exceptions to the foregoing requirements for Saloon, single seater and Sports Cars are as follows:

1.5.1. ROPS manufacturers may make application to Motorsport UK for a Roll Over Protection System (ROPS) Certificate to be issued.

Note: ROPS manufacturers wishing to make application for such a certificate should contact the Motorsport UK Technical Department in order to obtain details of the requirements to be met and the fees payable. Subject to these requirements being met a ROPS Certificate will be raised and issued. Duly authorised copies of this certificate containing a drawing, photographs, a copy of the manufacturers declaration that the ROPS meets the required regulations should be available to event Scrutineers.

1.5.2. Each ROPS manufactured after 1.1.97 for which Motorsport UK or the FIA has issued a ROPS (Rollcage) Certificate must bear an identification plate which details the manufacturer and the manufacturer's part number allocated to the cage. Details of this identity plate are to be included on the ROPS (Rollcage) certificate.

Vehicle Categories Covered

1.6.1. Series Production, Touring and Sports Cars.

- (a) Production cars, Touring Cars, Sports cars up to 2,000cc – Basic rollbar/rollcage complying with K1 or K2.
- (b) Production Cars and Touring Cars over 2,000cc – Rollbar/rollcage complying with K3 or K4.
- (c) Sports cars over 2,000cc – Rollbar/rollcage complying with K3 or K4 or K60(i) & (ii) and K31.

The different possibilities of installing the optional reinforcing members to the rollcage are shown in drawings K7 to K12.

Each type of reinforcement (drawings to K7 to K12) may be used separately or combined with one or several others).

These reinforcements can be installed in each of the basic rollcages (drawings K1 to K4).

Material

As defined in 1.4.

Note: For all the ROPS which are FIA homologated after 1.1.2000 for Touring cars, the presence of the ROPS in the door aperture must comply with the following criteria (see drawing No. 43 in this section).

Dimension A must be a minimum of 300mm.

Dimension B must be a maximum of 250mm.

Dimension C must be a maximum of 300mm.

Dimension D (Measured from the upper corner of the windscreen, without the seal) must be a maximum of 100mm.

Dimension E must not be more than half height of the door aperture.

Motorsport UK Certified and non-homologated ROPS constructed after 1.1.2001 in accordance with drawing 12 must also comply with the above dimensions.

Vehicles of Periods A-Z as defined within the current FIA yearbook for which a valid FIA Historic Technical Passport (HTP) has been issued – be fitted with a rollbar/rollcage as specified within the HTP issued for each individual vehicle and with that vehicle being in compliance with that specification.

1.6.2. Sports Racing Cars

The rollbar must conform to drawings K60(i) and K31. Forward facing stays are permitted for open Sports Racing Cars.

Minimum height 92cm measured along the line of the driver's spine from the bottom of the car seat.



'Corbeau has always been my seat of choice'

Ash Sutton
4 times BTCC Champion



FIA 8862-2009
4 Point & 6 Point Seats



FIA 8855-2021
Available in standard & large
Tall versions of both size available



Full Range of
FIA 8855-1999 Seats

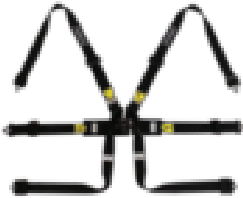

6 Point Formula Harness
8853-2016



6 Point HANS Harness
8853-2016



4 Point FIA Harness
8854/98

Make sure your equipment is in date for the 2024 season.
Especially if you are racing abroad.

corbeau-seats.com sales@corbeau-seats.com +44(0)1424 854499

Material

Cold drawn seamless Carbon Steel 350N/mm²

Minimum dimensions (mm)

45 x 2.5 (1.75in x 0.095in) or
50 x 2.0mm (2.0in x 0.083in).

1.6.3. Single Seater Racing Cars

The rollbar must be symmetrical about the lengthwise centre-line of the car and of minimum height 90cm measured vertically from the base of the cockpit or 92cm measured along the line of the driver's spine from the bottom of the car seat. There must be at least one brace rearwards from the top of the rollbar at an angle not exceeding 60° with the horizontal, this brace must be the same diameter as the rollbar, if two braces are fitted to the tube the diameter may be reduced to 26mm x 2.5mm (1in x 0.095in). Where two braces are fitted, they may be rearward or forward facing.

The width inside the roll-over bar main tubes must be 38cm minimum measured 60cm above the base of the seat. It must incorporate a crossbrace to restrain the driver's head and give rearward support. The top hoop radius must not be less than 10cm measured at the centre line of the tube.

Material

Cold drawn seamless Carbon steel 350N/mm²

Minimum dimensions (mm)

Vehicles up to 470kg:
38 x 2.5 (1.5in x 0.095in) or
40 x 2.0 (1.6in x 0.083in).
Vehicles 470kg and over:
45 x 2.5 (1.75in x 0.095in) or
50 x 2.0 (2.0in x 0.083in).

1.6.4. Other Considerations

- (a) An effective rollbar must be fitted with its top edge not less than 5cm above the helmet of the normally seated driver. It must be wider than the driver's shoulders at that height. It must be constructed of good quality seamless steel tubing of minimum 35mm diameter and wall thickness of 2mm. It should have the top bar straight or slightly curved but no tubes meeting in an inverted 'V'. It must be effectively braced to structural members.
- (b) Non-standard cars are advised to fit a rollbar to the following minimum requirements. Minimum height 72cm from the rear of the uncompressed seat cushion. It must have minimum flat width of 38cm running into radiused corners and affording driver and passenger equal protection.

It must be effectively mounted and braced to structural members forward and aft of the cockpit and not less than cockpit width. It must be constructed of good quality seamless steel tubing of minimum 32mm diameter and wall thickness of 1.5mm.

1.6.5. ALL aluminium alloy Roll Cages are prohibited.

1.6.6. It is recommended that rollbar/rollcage tubes within 150mm of a vehicle occupant's helmet are covered with a suitable energy absorbing material. A number of suitable materials are homologated by the FIA who publish specific regulations for the fitment of such materials for vehicles participating in International Events.

Aerodynamics

1.7. The use of a rollbar to achieve or supplement aerodynamic effects is prohibited.

Future

1.8. It is to be noted that the FIA publishes Regulations concerning ROPS for use in International competition. Motorsport UK aligns itself with these regulations wherever possible.

Seats, Seat Belts and Headrests

2.1. All seat safety belts must be complete units sourced from a recognised manufacturer and fitted in accordance with the manufacturers' instructions, Motorsport UK recommendations or FIA requirements. (See Drawing Nos. 39, 40, 41, 42 and 44.)

Where the vehicle manufacturer's standard safety belts and associated fitments are not utilised, bolts must be steel and of a minimum 7/16in UNF or M12 (grade 8.8) or, for an FIA homologated harness, as specified by the harness manufacturer.

2.1.1. Three point. Either one diagonal shoulder strap and one lap strap, or two merged shoulder straps and one lap strap bearing an ECE 'E' mark. With three anchorage points on the chassis/body shell or roll over bar of the vehicle on either side and to the rear of the driver's seat.

2.1.2. Four point. Two shoulder straps and one lap strap, with four anchorage points on the chassis/body shell or roll over bar of the vehicle, one either side of the driver and two to the rear of the driver's seat.

2.1.3. Five point. Two shoulder straps, one lap strap and one strap between the legs with five anchorage points on the chassis/body shell or roll over bar of the vehicle, one either side of the driver, two to the rear of the driver's seat and one between the legs.

2.1.4. Six Point. Two shoulder straps, one lap strap and two straps between the legs, with six anchorage points on the chassis/body shell or roll over bar of the vehicle, one either side of the driver, two to the rear of the driver's seat and two between the legs.

2.1.5. Where safety harnesses are mandatory it is recommended that those described in 2.1.2, 2.1.3 and 2.1.4 are homologated by the FIA and carry their label.

2.1.6. It is permitted to make a hole in series production seats to allow secure anchoring of seat belts.

2.1.7. All seat belts used on International Events must be homologated by the FIA, and carry their label.

For national events, where Specific Regulations require an FIA Homologated harness, harnesses homologated by the FIA according to FIA standard 8853-2016 may be used for up to five years after the year stated on the label.

Harnesses homologated by the FIA according to FIA standards 8853/98 and 8854/98 may be used until 31st December of the year stated on the label.

Harnesses homologated by the FIA will display the FIA Homologation Label on the left shoulder strap.

2.1.8. It is not permitted to mix parts of seat belts. Only complete sets as supplied by manufacturers are to be used.

2.1.9. Only one release mechanism is permitted on each seat belt configuration and this must be available for the wearer to operate whilst seated in the competing position.

CAGED LASER ENGINEERING

**Automotive Engineering and Fabrication Specialists
Bespoke & Standard Roll Cages**



ROLL CAGE
FABRICATION



CHASSIS
FABRICATION



RACE CAR
PREP



PIT
EQUIPMENT



POWDER
COATING



MACHINING



SHEET METAL
WORK



CNC
FOLDING



LASER
CUTTING



DESIGN

Market leaders in roll cage and chassis fabrication

**Producing bespoke and standard roll cages, designed,
manufactured and finished to the highest standard all under one roof**

All roll cages are Motorsport UK and FIA approved



motorsport uk

Unit 12
Ash Farm
Business Park
Holcombe
Radstock
BA3 5EX

+44 (0) 1761 239133
info@cagedlaser.co.uk
www.cagedlaser.co.uk

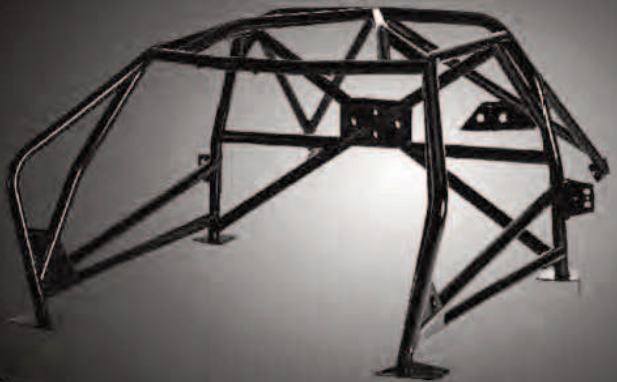

2.1.10. The anchorage points to the rear should be positioned so that the strap from the shoulder is as near horizontal as possible. It should not be located on the floor directly behind the driver/co-driver.

2.1.11. Seat belts once involved in a serious accident should be discarded as they are likely to have stretched. Belts subjected to oil, acid or heat should be replaced.

2.1.12. Elastic devices attached to the shoulder strap are forbidden.

2.2. Seats. All seats should be correctly located and securely anchored in such a way as to allow no movement in squab or backrest. When installing a Competition Seat, carry out the following checks before selection or purchase:

- Study the requirements of the vehicle concerned and ask the manufacturer's advice and recommendations.
- Check that the seat is suitable for the type of forces to which it could be subjected. These will include fore and aft and lateral loadings.
- Check that the seat carries full instructions for installation in your vehicle.
- Check that suitable mounting installations are available from the manufacturer.
- Ask the manufacturer to confirm that the seat frame is suitable for your Motor Sport discipline.
- If the original seat attachments or supports are changed, the new parts must either be approved for that application by the seat manufacturer or must comply with the following specifications (see drawing No. K32).

2.2.1. Supports must be attached to the shell/chassis via at least 4 mounting points per seat using bolts with a minimum diameter of 8mm and counterplates, according to drawing No. K32. The minimum area of contact between support, shell/chassis and counterplate is 40 sq cm for each mounting point. In Series Production Cars manufacturers' standard seat mounting points may be used. If quick release systems are used, they must be capable of withstanding vertical and horizontal forces of 18000N, applied non-simultaneously. If rails for adjusting the seat are used, they must be those originally supplied with the homologated car or with the seat.

2.2.1.1. For new build vehicles from 1st January 2021, where transverse seat mounting rails are used, they must be compliant with drawing No. K64(a) or homologated by the FIA or an FIA recognised ASN. The end plates may alternatively be welded to the counterplate. Multiple mounting holes, to a maximum of 4 at each mounting point, are permitted as shown in K64 (b)-(c).

2.2.1.2. Drawing K64 (a)-(c) Material specification:

Tube

Cold Drawn Seamless Unalloyed Carbon Steel
Minimum Yield strength 350N/mm²
Minimum dimensions 35mm square x 2.5mm wall thickness

Box Section (Structural)

Unalloyed Carbon Steel
Minimum Yield Strength 350N/mm²
Minimum dimensions 35mm square x 2.5mm wall thickness

2.2.1.3. Any mounting holes drilled in the seat rails must have bushes installed, these must be fully welded. The bushes must be profiled to prevent them being pulled through, alternatively they may be of 'top hat' type inserted from below. Minimum bush diameter 13mm for M8 bolts, 15mm for M10 bolts. Multiple bush position are permitted.

2.2.1.4. The minimum overall length of the "U" shape extruded section is 50mm with a 2.5mm wall thickness. Each mounting point must be capable of withstanding a force of 15000N applied in any direction.

2.2.2. The seat must be attached to the supports via 4 mounting points, 2 at the front and 2 at the rear of the seat, using bolts with a minimum diameter of 8mm and reinforcements integrated into the seat.

2.2.3. The minimum thickness of the supports and counterplates is 3mm for steel and 5mm for light alloy materials. The minimum longitudinal dimension of each support is 6cm.

2.3. Headrests. On all vehicles where it is not mandatory (13) it is strongly recommended that a head restraint in the form of a headrest be fitted, as near to the driver's/co-driver's helmet as possible, to prevent whiplash of the neck and spine in case of impact. It is recommended that they comply with 13.

Fire Extinguishers

3.1. Plumbed-In Fire Extinguisher Systems

3.1.1. Where a plumbed-in fire extinguisher system is required the vehicle must be equipped with an extinguishing system in compliance with FIA Standard for plumbed-in Fire Extinguisher Systems in Competition Cars (1999) or with FIA Standard 8865-2015 or 8876-2022 (for single seaters).

The system must be used in accordance with the manufacturer's instructions and with FIA Technical Lists n°16 or n°52 or n°97.

In rallies, the minimum quantity of extinguishant for systems of FIA Technical List n°16 must be 3 kg.

3.1.1.1. For Electrified Vehicles see (J) Appendix 2 5.30.5 to 5.30.8.

3.1.2. All extinguisher containers must be adequately protected and must be situated within the cockpit.

The container may also be situated in the luggage compartment on condition that it is at least 300 mm from the outer edges of the bodywork in all horizontal directions. It is prohibited to mount bottles outside the main structure.

3.1.3. It must be secured by a minimum of 2 screw-locked metallic straps and the securing system must be able to withstand a deceleration of 25 g.

Anti-torpedo tabs are required.

The material of the securing system must operate within the -15°C to +80°C temperature range.

All extinguishing equipment must withstand fire.

Plastic pipes are prohibited and metal pipes are obligatory (unless specified otherwise). The system must work in all positions.

3.1.4. The system should have two points of triggering, one for the driver (and Co-driver in Rallies) and one outside the car for activation by Marshals etc.

3.1.5. The driver (and co-driver where applicable) must be able to trigger the extinguishing system manually when seated normally with their safety harnesses fastened and the steering wheel in place.

3.1.6. The triggering point from the exterior must be positioned close to the Circuit Breaker (or combined with it) and must be marked by the letter "E" in red inside a white circle of at least 10cm diameter with a red edge.

EXTINGUISHER EXPERTS

FOR RACING & MOTORSPORT

FEV is a UK based family business, we have been manufacturing market leading FIA fire suppression systems for over 30 years. Our products are chosen by major motorsport manufacturers and teams worldwide and we continue to supply all level and classes of racing in the UK.

- » All systems FIA homologated meeting Motorsport UK regulations
- » UK approved service agents
- » Fast turnaround times for supply of high quality fire suppression products
- » A product range to meet weight and space saving requirement's
- » We are the leading supplier of systems to manufacturers and teams at top level motorsport, a brand recognised for quality and reputation

THE NEXT GENERATION

Introducing the 2023 CF-TEC range, offering the most cost effective solutions to meet FIA Standards 8865 and new 8876 for open cockpit vehicles.

- » Mechanical and electrical activation options for FIA Standard 8865
- » Fast fire out times with weight and packaging advantages
- » Cutting edge Coldfire agent removes extreme heat, prioritising safety and the environment



01243 555566
WWW.F-E-V.CO.UK
SALES@F-E-V.CO.UK

FIRE EXTINGUISHER VALVE COMPANY LTD

UNIT B3 FORD AIRFIELD INDUSTRIAL ESTATE,
FORD, WEST SUSSEX. BN18 0HY



FIRE SUPPRESSION

3.1.7. Extinguisher nozzles must be suitable for the extinguishant and be installed in such a way that they are not directly pointed at the occupants' heads.

3.2. Hand-held extinguishers

3.2.1. Where a hand-held fire extinguisher is required the vehicle must be equipped with at least one fire extinguisher in compliance with 3.2.2 to 3.2.7 hereunder or with FIA Standard 8865-2015 (Articles 3.2.2 to 3.2.5 hereunder do not apply in the latter case).

3.2.2. Permitted extinguishants:

AFFF, Clean Agent, powder or any other extinguishant homologated by the FIA.

3.2.3. Minimum quantity of extinguishant:

- AFFF foam (includes: FireSense, Zero 2000, F-TEC etc) 2.4 litres
- Gas (includes: Novec 1230, FX G-TEC/N-TEC, Viro3, Zero 360, Extreme etc) 2.0 kg
- Powder 2.0 kg

3.2.4. All extinguishers must be pressurised according with the manufacturer's instructions. Powder extinguishers must be pressurised to 8 bars minimum, 13.5 bars maximum. Furthermore, each extinguisher must be equipped with a means of checking the pressure of the contents.

3.2.5. The following information must be visible on each extinguisher:

- Capacity
- Type of extinguishant
- Weight or volume of the extinguishant
- Date the extinguisher must be checked, which must be no more than two years after either the date of filling or the date of the last check, or corresponding expiry date.

3.2.6. All extinguishers must be adequately protected.

Their mountings must be able to withstand a deceleration of 25g. Furthermore, only quick-release metal fastenings (two minimum), with metal straps, are accepted. Anti-torpedo tabs are required. It is prohibited to mount bottles outside the main structure.

3.2.7. The extinguishers must be easily accessible for the driver and the co-driver.

3.3. During events:

3.3.1. All plumbed-in extinguisher systems must be in an 'ARMED' condition (i.e. be capable of being operated without the removal of any safety device) at all times whilst competing or practising in races or speed events (including during post-event scrutineering), and at all times that crash helmets are worn on rallies (i.e. on Stages etc.).

3.3.2. Any plumbed-in extinguisher system found to be incapable of being operated will be the subject of a report to the Clerk of the Course/Stewards for possible penalty as an offence against Safety Regulations.

3.3.3. Checking for correctly 'Armed' extinguisher systems, should only be carried out by Motorsport UK Scrutineers, and/or Judges of Fact nominated for that purpose.



MOTORSPORT FIRE EXTINGUISHERS

4kg Haylo Mechanical/Electrical

Plumbed in saloon car system FIA Approved to Technical list I6 EX057.I9



4.25L AFFF Mechanical/Electrical

Plumbed in saloon car system FIA Approved to Technical list I6 EX056.I9



2 & 3 Kg Haylo Hand Held

Haylo is a Halon replacement extinguishing medium



2.4 Litre AFFF Hand Held

Motorsport UK compliant our AFFF uses Aerospace grade aqueous foam



Lighter. Better. Faster.

The ultimate in fire suppression systems

With even faster and more efficient deployment of extinguishant, all systems have been homologated to conform to either FIA Technical list numbers 16 or 52, making them the most advanced in the world.



zefo[®] 2020 **zefo[®] 360** **zefo[®] 275** **zefo[®] EV**

- All systems FIA Homologated
- Excellent fire knock down and fire out capabilities
- Smaller and lighter than ever
- Two year service cycle
- Constant discharge in any orientation
- The choice of world championship winning constructors

Lightweighting driver safety technology

RACE HARNESSSES



RACE MIRRORS



QUICK RELEASE STEERING BOSSES



RAIN LIGHTS



ROLL CAGE PADDING



▶ Check out our **Overview** and **Safety** videos on the website homepage www.lifeline-fire.co.uk

DESIGNED AND MADE IN COVENTRY, UK

Champions of Safety
www.lifeline-fire.co.uk

30
YEARS
1974-2024

lifeline

Fire & Safety Systems Ltd.

Safety Fuel Cells

4.1. The FIA approved standard for Safety Fuel Cells is FIA/Spec./FT.3 and FT.5. Fuel cells complying with this standard are only manufactured by authorised companies and bear the name of the company, specification, code and date of manufacture stencilled on each cell. No other cells are approved by the FIA.

4.2. Under FIA regulations the homologation expires once the cell is five years old. The validity of this homologation may be extended for a further two years if the cell is inspected and recertified by the original manufacturer.

4.3. It is recommended that any safety cell is periodically inspected on a regular basis.

Red Warning Light

5.1. A rearward facing red warning light of a minimum of 21 watts, with surface area minimum 20cm², maximum 40cm², or of 21 watts with a surface area minimum of 50cm² and with lens and reflector to EU Standards, must be located within 10cm of the centre line of the vehicle and be clearly visible from the rear. Vehicles fitted with full width bodywork may alternatively use two lights equally located about the vehicle centre line. An alternative light unit of equal or enhanced constant luminosity or LED lights that are either homologated by the FIA or comply with relevant EU Regulations may be used.

5.2. The warning light must be switched on when visibility conditions are reduced, or as detailed within championship and/or event regulations, or when so instructed by the Clerk of the Course.

Tank Fillers, Vents and Caps

6. Tank fillers and caps must not protrude beyond the bodywork or be situated within the driver/passenger compartment. The caps must have an efficient locking action to reduce the risk of opening during an accident and to ensure closing after refuelling (14.1.2). Air vents must be at least 25cm to the rear of the cockpit and must be designed to prevent the escape of fuel should the vehicle be inverted. It is recommended that a non return valve is incorporated in the vent system. The entire fuel tank area 'licked by the open air stream' must incorporate a crushable structure as follows:

Crushable Structure

7.1. The crushable structure should be a sandwich construction based on a fire resistant core of minimum crushing strength 25lb/sq in. It is permitted to pass water pipes through this core.

7.2. The minimum thickness of the sandwich construction must be 10mm. The fore and aft fuel tank area, however, must provide for a crushable structure of at least 100mm thickness at its thickest point, the position of this widest point to be at the constructor's discretion, over a length of at least 35cm after which it may be generally reduced to 10mm.

7.3. The sandwich construction must include two sheets of 1.5mm thick aluminium sheet having a tensile strength of 14 tons/sq in and minimum elongation of 5%.

7.4. All oil tanks mounted outside the main chassis structure must be surrounded by crushable structure of minimum thickness 10mm.

External Circuit Breaker

8.1. The circuit breaker, when operated, must isolate all electrical circuits with the exception of those that operate fire extinguishers.

8.1.1. Any re-set of the circuit breaker must be operated by a distinct different action to the trigger.

8.2. The triggering system for the circuit breaker on saloons should be situated at the lower part of the windscreen mounting, preferably on the driver's side or below the rear window.

8.3. On Open Cars the triggering system should be situated on the lower main hoop of the Roll-over Bar on the driver's side or at the lower part of the windscreen mounting (as above).

8.4. Alternatively on cars of Periods A to F the mounting point may be mounted approximately vertically below the line of the scuttle on the driver's side.

8.5. The triggering system location must be identified by a Red Spark on a White-edged Blue triangle (12cm base), with the 'On' and 'Off' positions and method of triggering (Push, Pull, or a Rotation direction indicated by an arrow) clearly marked.

Overalls

9.1. Clean Flame-Resistant overalls, must be worn to cover from ankle to wrist to neck.

Acceptable standards:

9.1.1. Racing:

FIA 8856-2018

FIA 8856-2000

9.1.2. Special Stage Rallies, Sprints and Hill Climbs:

FIA 8856-2018

FIA 8856-2000

FIA 1986 Standard

9.1.3. Karting:

As defined in U.13.3.

9.1.4. All Other Events (including overalls in accordance with Q.12.25.2):

BS6249 part 1 Index A or B (but not part C).

BSEN533

EN533:1995 Index 3

ISO 14116

FIA 8856-2018

FIA 8856-2000

FIA 1986 Standard.

9.1.5. For FIA Standard Overalls the homologation label will be stitched into the fabric of the garment or on a sewn in label. For International use overalls must comply with FIA Appendix L.

CARTEK electronic Battery Isolators are a very small and highly reliable alternative to the traditional mechanical master-switch.

They have been designed to overcome all of the problems and restrictions associated with mechanical and electro/mechanical master-switches to maximise reliability, enhance safety save weight and simplify installation.



USED BY



OPEL ADAM R2



ADESS LMP3



SUBARU GRC



MINI CHALLENGE UK

FEATURES

- Fully electronic with no moving parts
- Totally sealed against water and dirt
- Completely resistant to shock and vibration
- Fully integrated with built in alternator run-down circuitry - **No extra components required**
- Driver operation by a single internal ON-OFF button/switch
- External operation by single or multiple 'strike' button(s) (meets Motorsport UK Regulation K 8.1.1)
- Buttons / switches connected to Isolator using light weight wiring
- Mounts close to battery for reduced cabling
- Very small and weighs just 70g - 140g
- Designed and manufactured in UK using the latest and best quality components available

ALSO FROM CARTEK:



POWER DISTRIBUTION
PANELS



GEAR INDICATORS

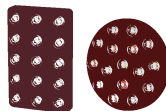

FIA RAIN LIGHTS
2019 SPEC



SHIFT LIGHTS

For more information please go to :

www.CARTEKMOTORSPORT.com

9.1.6. As with any item of safety equipment, evidence of damage or excessive wear can render it unsuitable for use. In the case of overalls this could include over frequent, or incorrect, washing, broken seams or stitching and worn patches. Two piece overalls should be avoided, but if worn must overlap and provide flame resistant coverage.

9.1.7. Due to the complex nature of national test standards and variations of detailed testing it is not possible to quote 'equivalents' from foreign national standards unless they are FIA approved as detailed above.

National test standards are in the process of being superseded by European norms (CE Marks), which will provide a common standard throughout Europe.

9.1.8. Individual competitors are responsible for ensuring their own safety and that appropriate flame resistant overalls are worn when mandatory.

9.1.9. Competitors are also strongly advised to wear Flame Resistant gloves, socks, balaclavas and underwear.

Plastic shoes (such as trainers) should be avoided.

9.1.10. Specific regulations concerning Flame Resistant gloves, socks, balaclavas and underwear are published by the FIA and applicable to International events.

9.2. Exceptionally, drivers of open bodywork Period Defined Vehicles (Non-Rally) A-D and pre-1941 three wheeled cars, may wear ACU or FIM approved leather overalls which must have a minimum thickness of 1.2mm at any part of the suit, or overalls approved by the FIA for Karting on Long Circuits.

9.3. When a name appears on a driver's helmet or overalls, this must be the name of the person wearing them.

Crash Helmets

10.1. Crash helmets bearing an MSA/Motorsport UK approval sticker must be worn at all times during training, practice and competition. The user must ensure that the helmet is to a standard currently specified (10.3.1), that it fits properly, is secured properly and that it is in a serviceable condition. It is strongly recommended that a flame resistant balaclava, helmet bib or face mask also be worn.

10.2. Total protection can never be given by any headgear, and the best of crash helmets may not entirely prevent head injury or death in a severe accident. Helmet users must understand that helmets are deliberately constructed so that the energy of a severe blow will be absorbed by the helmet and thereby partially destroy it. The damage may not be readily apparent; it is essential therefore that any helmet receiving a blow in an accident is either replaced or returned to the manufacturer for competent inspection – this of necessity must be the responsibility of the helmet user, who will have been aware of the circumstances under which the helmet was struck. It is not possible nor indeed reasonable to expect the scrutineer, in every case, to observe significant damage. Where there is any doubt about the helmet's fitness for its intended purpose then the Chief Scrutineer is empowered to remove the MSA/Motorsport UK Approval Sticker and impound the helmet for the duration of the meeting. This should be a rare occurrence since competitors must appreciate that, once a helmet has served its purpose, it is not only sensible but necessary to replace it. It is the competitor themselves who must ensure that the helmet which they use is fully fit for its purpose; it is clear that this is a small insurance to pay for one's life. The competitor also might consider that, should they survive an accident, but receive head injuries having knowingly used a previously damaged helmet, they could be placing an enormous burden of care upon their family.

10.2.1. Impounding of helmets

Case 1 Pre-Event. If the helmet does not conform with the required Standards or is in a poor or dangerous condition, the Chief Scrutineer will impound the helmet for the duration of the Meeting, removing the MSA/Motorsport UK sticker. At the close of the Meeting the helmet will be returned, as received, with the exception of the MSA/Motorsport UK sticker, to the competitor concerned.

Case 2 Accident during the Event. If the competitor is injured and the helmet is damaged, the Chief Scrutineer will impound the helmet and remove the MSA/Motorsport UK sticker then seek the advice of the Steward as to further action.

Case 3 Accident during Event and competitor evacuated to hospital with head injuries. The Chief Scrutineer will make sure that the helmet has been seen by the Chief Medical Officer, they will then impound the helmet and remove the MSA/Motorsport UK sticker. Unless the Chief Medical Officer wishes to retain the helmet it must be despatched to the Technical Department at Motorsport UK. Unless specifically called for by the competitor it will be disposed of after six weeks.

10.3. The competitor is reminded of the following essential criteria when buying or using their helmet:

- (a) Correct Standard.
- (b) Correct Fit.
- (c) Security.
- (d) Condition.

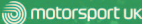

BE THE CHANGE

Scan below to learn about how you can help to make our sport more sustainable



motorsportuk.org/about-us/environmental-sustainability



f t i Araimotorsportuk #WhyArai #fastesthelmets

THE MAGNIFICENT GP-7

FRP SA 2020
SRC
SRC ABP

FOR OVER 70 YEARS ARAI HAVE BEEN CREATING THE HARDEST, STRONGEST AND SAFEST HELMETS POSSIBLE. BORN FROM A PHILOSOPHY TO CREATE THE VERY BEST, EVERY ARAI IS HANDMADE BY SKILLED JAPANESE CRAFTSMEN.



GP-7 FRP SA 2020



GP-7 SRC



GP-7 SRC ABP

2023 BTCC CHAMPION ASHLEY SUTTON



10.3.1. Standards. Helmets bearing one of the under mentioned 'standards' may be approved by Motorsport UK subject to other criteria being met. See also drawing 10.3.1.

- (a) ALL MOTORSPORT UK NATIONAL EVENTS
 - FIA 8860-2010
 - FIA 8859-2015
 - FIA 8860-2018
 - FIA 8860-2018-ABP
 - SNELL SA2015 (Not valid after 31.12.26)
 - SNELL SA2020
- (b) In addition the following are acceptable for:
 - Motorsport UK National Kart Racing Events (with exception of Kart Drivers under 15 years of age, Cadet and Bambino Drivers) and Motorsport UK National Junior Drag Racing:
 - SNELL K2015
 - SNELL K2020
 - SNELL – FIA CMR2007
 - SNELL – FIA CMS2007
 - SNELL – FIA CMR2016
 - SNELL – FIA CMS2016
- (c) For all International Events please refer to the FIA Regulations.

Kart Drivers under 15 years of age, Cadet and Bambino Drivers. The weight of the helmet may be checked at any time during an event and must not weigh more than 1,550g:

- SNELL – FIA CMR2007
- SNELL – FIA CMS2007
- SNELL – FIA CMR2016
- SNELL – FIA CMS2016

Part of the approval procedure is to affix a Motorsport UK sticker to the outside of the helmet in the approximate location of the driver's right ear. Stickers may only be affixed by selected scrutineers, by Motorsport UK at Motorsport UK House, or by selected manufacturers, after the helmet has been checked for conformity with the standard required and is considered to be in a satisfactory condition.

MSA/Motorsport UK approval stickers, for which a fee of £2.50 is charged, are printed on foil, and once individually affixed, cannot be reapplied. Note: Stickers supplied since 01/01/08 are individually numbered.

Note that helmet standards are regularly reviewed and updated, and superseded. Standards will periodically cease to be acceptable; hence an element of 'lifing' will always remain.

Helmets approved for use in all disciplines require a blue MSA/Motorsport UK sticker to be affixed. Helmets which are accepted for use in kart racing only require a green or yellow where applicable MSA/Motorsport UK sticker to be affixed. These stickers are available from issuing scrutineers.

SCHROTH RACING CHAMPIONS CHOICE

SCHROTH[®]
RACING



XLT CARBON



FIA Standard 8853-2016

**Wide Range of
FHR Devices,
Harness Belts
& Racing Nets**

Visit www.schroth.com/racing
to learn more about our products.



Follow us on Facebook
www.facebook.com/schrothracing

10.3.2. Fit and Security. To ensure satisfactory fit and security of your helmet, proceed as follows:

- (a) Obtain correct size by measuring the crown of your head.
- (b) Check that there is no side-to-side movement; a helmet should be as closely fitting as possible consistent with comfort.
- (c) Tighten straps securely – the chin strap must be under tension at all times; ensure therefore that the strap cannot slip. Chin cups are prohibited.
- (d) With head forward attempt to pull up the back of the helmet, to ensure the helmet cannot be removed in this way.
- (e) Ensure you can see clearly over each shoulder.
- (f) Make sure nothing impedes your breathing in the helmet and never cover your nose or mouth other than with a flame resistant balaclava or face mask. Helmets with life-support attachments must only be worn if they are connected to a life-support system.
- (g) Never wear a scarf, tie or other loose clothing which could come loose and possibly cause an accident.
- (h) Ensure that the visor can be opened with one gloved hand.
- (i) Satisfy yourself that the back of the helmet provides protection for your neck.
- (j) Do not buy from mail order unless you can satisfactorily carry out the above checks; return a helmet unused if it does not fit.

10.3.3. Condition and Care of Helmet

- (a) The user themselves must bear the prime responsibility for ensuring that their helmet is fit for the purpose intended, since significant damage to the helmet may have been sustained without this being apparent to the scrutineer.
- (b) Anything other than minor superficial damage is likely to result in the scrutineer removing the Motorsport UK sticker and impounding the helmet for the event.
- (c) It is in everyone's interest for the competitor to buy the best helmet they can and to look after it (the best is not necessarily the most expensive). A helmet bag should always be used.
- (d) There must be no alteration to the structure of a helmet. Where a radio intercom is fitted this should only be done in accordance with the helmet manufacturer's instructions. Fitment of cameras to helmets by whatever means is not permitted unless an integral camera is provided by the helmet manufacturer and that model of helmet is approved under one of the accepted standards.
- (e) Use only a weak solution of soft soap and water to clean the interior and exterior of the helmet; do not get the interior too wet.
- (f) Some moulded plastic helmets although they meet approved standards can be seriously damaged by substances such as petrol, paint, adhesives, cleaning agents and stickers (not the Motorsport UK stickers) – such damage may not always be apparent; however, crazing or obvious dulling of the surface finish could indicate serious structural weakening of the helmet and is likely to result in the scrutineer removing the Motorsport UK sticker and impounding the helmet for the event.

- (g) The helmet should be stored, preferably in a helmet bag, in a cool dry place away from sunlight when not in use. Do not strap the helmet to the roll cage or allow other unrestrained movement which could cause the helmet to be damaged.
- (h) A good helmet, properly cared for, is one very important link in a long chain of safety measures. Do not allow it to become the weak link. Do not rely on others. You are responsible for your own safety. Do not, through your own fault, become a grave burden to others.

10.4. FHR Device

It is permitted to incorporate the use of an FIA approved FHR Device fitted in accordance with FIA regulations and the below.

For Motorsport UK National Events in addition to helmets listed by the FIA as recognised for use with FHR, helmets to Snell SA2015, Snell SA2020 are accepted subject to the anchorage points being marked as homologated to FIA 8858-2010.

10.4.1. Part of the approval procedure is to affix an Motorsport UK sticker to the yoke of the FHR device.

Stickers may only be affixed by selected scrutineers, by Motorsport UK at Motorsport UK House, or by selected manufacturers, after the FHR device has been checked for conformity with the standard required and is considered to be in a satisfactory condition.

Motorsport UK approval stickers, for which a fee of £2.50 is charged, are printed on foil, and once individually affixed, cannot be reapplied. Note: Stickers are individually numbered.

Where there is any doubt about the device's fitness for its intended purpose then the Chief Scrutineer is empowered to remove the Motorsport UK Approval Sticker and impound the FHR Device for the duration of the meeting.

The FHR Device may also be impounded by the Chief Scrutineer in the same cases as the helmet per 10.2.1.

Goggles and Visors

11.1. Either goggles or a visor must be worn at all times during training, practice and competing, unless in a closed vehicle.

11.2. Recommended visor and goggles standard (minimum) BS4110, BS4110:1999, BS EN 1938, European Standard 89/686/EEC.

11.3. Goggles or visors must be clear or neutral density filters.

Front Engine Cars

12. With front engine cars a propeller shaft restraint should be fitted. Either safety hooks or a rigidly fixed steel panel of not less than 18swg.

Head Restraints

13. Head restraints when required to be fitted, must be capable of restraining a 17kg mass decelerating at 5g.

Dimensions to be 10cms x 10cms and located such that the driver's/passenger's head/helmet is restrained and cannot move past it under rearward forces, or be trapped between the rollbar and the head restraint. It is recommended that it be within 5cm of the driver's/ passenger's helmet when they are normally seated.

General Safety Recommendations

14.1. Owing to the widely varying nature of competitions and the vehicles taking part in them, Motorsport UK takes the view that it would not be in the best interests of the competitors to cover all aspects of safety precautions with mandatory regulations. Inevitably such regulations could not necessarily provide for the most appropriate safety precautions in all foreseeable circumstances.

The Motorsport UK therefore draws attention to the following points so that the competitors can consider them and take precautions as seem appropriate to their own particular requirements.

14.1.1. Electrical

- (a) **Auxiliary Batteries** – precautions should be taken to reduce the possibility of acid burns from batteries in case of accidents. Auxiliary Batteries should be secured within a nonconductive leak-proof compartment.
- (b) **Electrical System** – all wiring should be secured and well protected to reduce the risk of fire from electrical short circuits.

14.1.2. Fuel

- (a) **Fuel Tanks and Pipes** – every effort should be made to isolate fuel tanks and pipes from the driver/passenger compartment. The risk of fuel spillage from accident damage can be reduced by use of bag type tanks or by coating metal tanks with GRP. Tanks should be located so that they are given maximum protection by the structure of the vehicle. Vents should be designed to avoid spillage if the vehicle becomes inverted.
- (b) **Fuel Fillers** – these should be designed and located to reduce risk of damage. Filler caps should not be liable to open in the case of an accident. Simple screw caps are effective. The positive locking of the fuel filler caps is recommended. The filler pipe to the tank should be of minimum possible length and not protrude beyond the bodywork (6).

14.1.3. Steering Wheels. The types least likely to inflict injuries due to breakage should be selected. Uncovered wooden rims should be avoided.









14.1.4. Fire Extinguishers. Even small extinguishers carried in a vehicle can extinguish or contain fires before they develop seriously. Minimum recommendation is for a 1.75 litre AFFF extinguisher or equivalent with BS4123/EN3 approval (EN3 minimum size is 2 litre AFFF) and a rating of at least 34B. More sophisticated equipment is required in many events and full vehicle systems are highly recommended (see 3).

FREE
£25 VOUCHER
with all MSUK Starter packs!



Grand Prix Racewear

SILVERSTONE

 RACE SUITS	 HELMETS	 BOOTS	 GLOVES
 UNDERWEAR	 HANS DEVICE	 KART WEAR	 LUGGAGE

SILVERSTONE CIRCUIT SHOWROOM

www.gprdirect.com

OPEN 7 DAYS

01327 855 585



SILVERSTONE CIRCUIT, TOWCESTER, NN12 8TN

4119 SERIES RACE SEAT

Deep shoulder support



Moulded ergonomic cushions

Cool air-ducting

Advanced lightweight shell construction

Back-mounting capability

Large harness guides



Cool air-ducting



“Study the requirements of the vehicle concerned and ask the manufacturer’s advice and recommendations”

Motorsport UK Yearbook 2024 [Competitors: Safety, sec 2.2 Seats]



FIA APPROVED HARNESSSES

- Lightweight alloy adjusters available
- 2-inch or 3-inch straps
- Wide range of colours



STEERING WHEELS

- 300, 330, 350mm diameter
- Suede leather
- Flat or dished

ROLLCAGE PADDING

- BSCI closed-cell foam
- FIA and SFI Approved
- 38mm to 45mm sizes



- All sizes are 900mm long

4100 SERIES SEATS

- Shell weight from just 5.8kg
- Series includes non-HR models
- 3 sizes to suit



APPROVED



14.1.5. Seats. See 2.2.

14.1.6. Headrests. See 2.3.

14.1.7. Radiator Caps. These caps should be positioned or shielded in such a way that hot water or steam cannot scald the driver of the vehicle if they become opened or broken in an accident.

14.1.8. Clutch and Bell Housing Protection. It is recommended that a shield be placed to guard the clutch/bellhousing and to protect in case of clutch/flywheel derangement. This can be a 1/8in steel plate, or sandbag type absorber as used in drag racing.

14.1.9. As a general principal competitors are advised to replace any safety item, helmet, safety harness, seats etc., should they have been involved in a severe accident.

14.2. Paddock Safety. In areas to which the public has access, no engine shall be run with the gears engaged whilst the vehicle has any driving wheels not in direct contact with the ground, unless all moving parts are adequately guarded and, with the exception of Karts, a competent person is seated in the driving seat.

14.3. Heat and Flame Resistant Clothing. Where appropriate and required by specific regulations the FIA standard is shown below, as detailed in FIA Yearbook, Appendix L, Chapter III, Article 2. These standards are advised for all competition use where protective clothing is either mandatory or recommended.

- (a) **Underclothing.** Materials tested to ISO 6940 or homologated to an FIA standard for protective clothing for automobile drivers. An indication of this should appear on the front of the upper garment, which must cover the neck.
- (b) **Balaclavas.** Materials tested to ISO 6940 or homologated to an FIA standard for protective clothing for automobile drivers. All the part seen in frontal projection when worn to consist of at least 2 layers of minimum 180 gr/m² each. The bottom of the balaclava to meet the requirements in (f).

- (c) **Socks.** Materials tested to ISO 6940 or homologated to an FIA standard for protective clothing for automobile drivers. Socks to be half hose (to mid-calf) and made from at least one layer minimum 180 gr/m².
- (d) **Shoes.** To cover the whole foot and ankle. Materials tested to ISO 6940 or homologated to an FIA standard for protective clothing for automobile drivers and fastenings and laces to be of non-fusible material. Soles to be manufacturer certified as resistant to hydrocarbons and to flames. Thread used to be flame resistant.
- (e) **Gloves.** Materials tests to ISO 6940 or homologated to an FIA standard for protective clothing for automobile drivers. Each glove to be labelled to that effect. Backs of gloves to be made from at least two layers of 180 gr/m². Thread must be flame resistant and non-melting. Gloves must be fitted at the wearer's wrist and cover the cuff of the wearer's overalls.
- (f) Where Motorsport UK/FIA regulations specify the wearing of protective clothing the labels on overalls and upper underclothing may be verified by the organisers for compliance with regulations.
- (g) Exceptionally, drivers of open bodywork Period Defined Vehicles (Non Rally) A-D and pre-1941 three wheeled cars, may wear ACU or FIM approved leather gloves and shoes which must have a minimum thickness of 1.2mm at any part of the garment, or gloves and shoes approved by the FIA for Karting on Long Circuits.

Officials shall also have the right to examine other articles of clothing subject of regulations upon request. Wearers are warned of the particular vulnerability of neck, wrists and ankles. Balaclavas must extend to enter inside the overalls or undergarment around the neck and not come free whichever way the head is moved. Upper undergarments should have a polo style neck.

Ankles and wrists should always be covered by at least two items of protective clothing.

HELP THE BRITISH MOTORSPORT TRUST CREATE A SAFER SPORT

The motorsport charity making a meaningful impact on the sport through UK motorsport training, safety and special projects.

INDUSTRY LEADING MARSHALS AND VOLUNTEER OFFICIALS TRAINING PROGRAMMES



SAFETY IMPROVEMENTS, RESCUE UNIT SUPPORT & INNOVATIONS



THE INTRODUCTION OF LIGHT PANELS AT UK CIRCUITS



**BRITISH
MOTORSPORT
TRUST**

britishmotorsporttrust.org



EST. 1977

SCAN TO MAKE
A DONATION



Appendix 1: Tables and Drawings

Drawing 10.3.1

Approval Sticker



Approval Sticker



Approval Sticker



Drawing 10.4.1



motorsport UK

Motorsport UK
141 The Command Works
Bicester Motion
OX27 8FY

Monday – Friday
09:00 – 17:00

01753 765000
hello@motorsportuk.org
motorsportuk.org



SPECTATE SAFELY!

- **Be alert!** Always expect the unexpected.
- Stay at the designated spectator areas.
- Remember that in an accident anything can happen.
- Always follow the instructions of the marshals.

**YOUR SAFETY
YOUR LIFE**



motorsportuk.org
#rallysafety



Drawing 10.3.1

HELMET STANDARDS



CMR2007



CMS2007

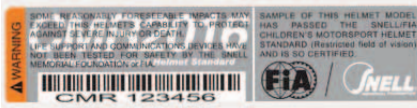

CMR2016



CMS2016



K2020



SA2015



K2015



SA2020

FIA

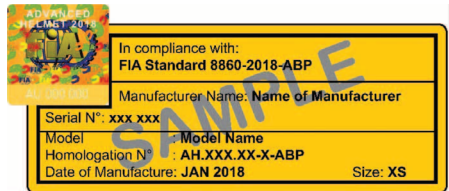
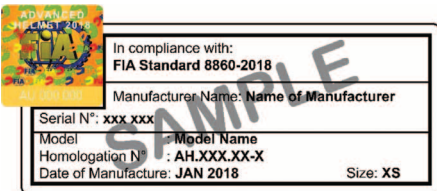
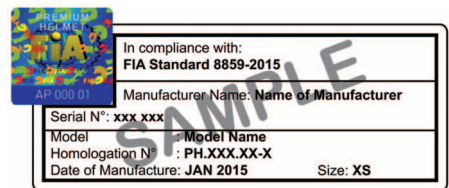
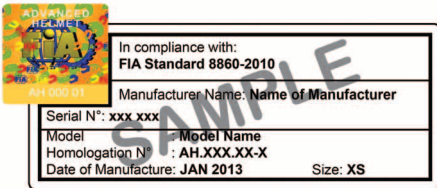

Appendix 2: Safety Cage Drawings

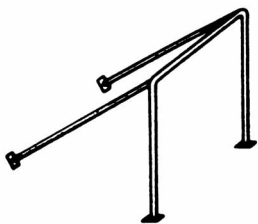

Drawing No. 1

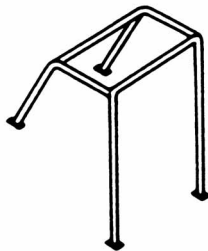

Drawing No. 2

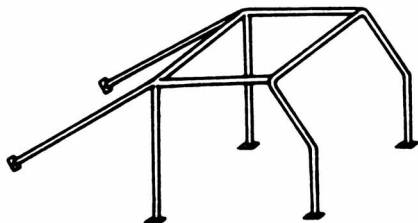

Drawing No. 3

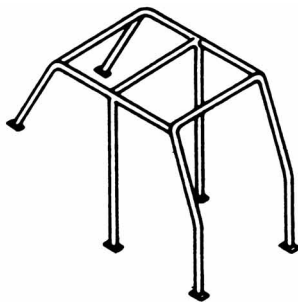

Drawing No. 4

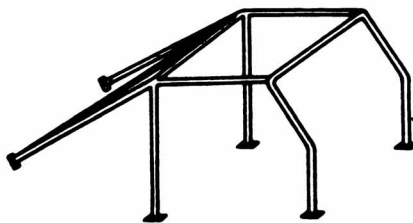

Drawing No. 5

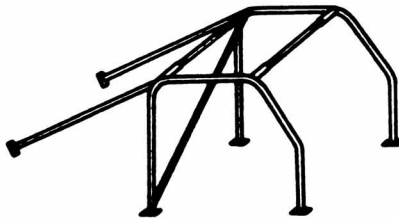

Note: Diagonal may be handed to left or right
Drawing No. 6

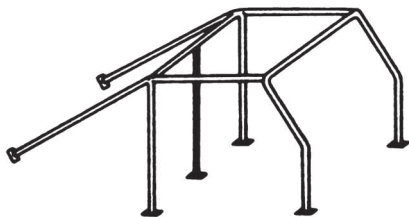

Drawing No. 7

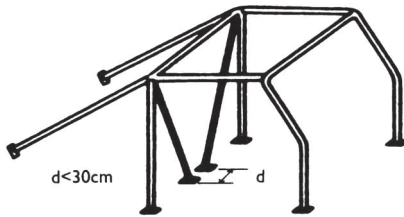

Drawing No. 8

SCHROTH RACING CHAMPIONS CHOICE

SCHROTH[®]
RACING



XLT CARBON



FIA Standard 8853-2016

**Wide Range of
FHR Devices,
Harness Belts
& Racing Nets**

Visit www.schroth.com/racing
to learn more about our products.



Follow us on Facebook
www.facebook.com/schrotracing

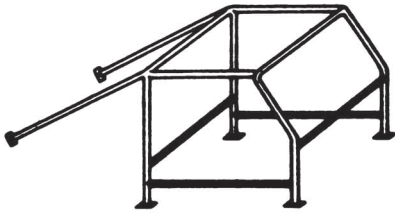

Drawing No. 9

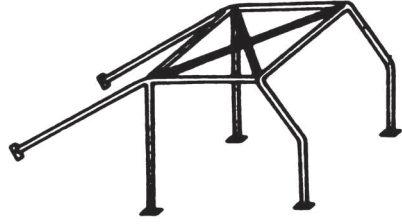

Drawing No. 10

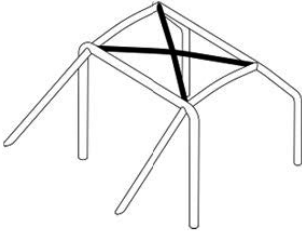

Drawing No. 10 (a)

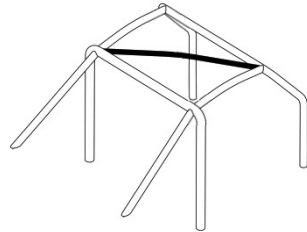

Drawing No. 10 (b) Bar may be fitted in either orientation

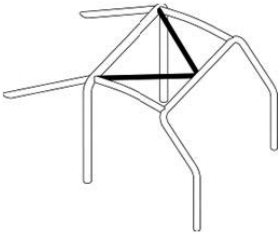

Drawing No. 10 (c)

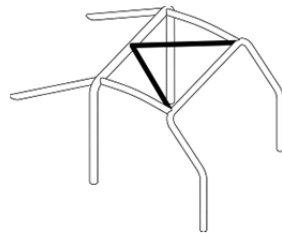

Drawing No. 10 (d)

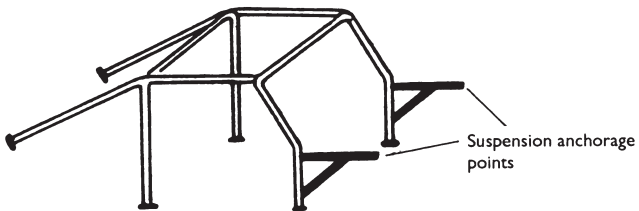

Drawing No. 11

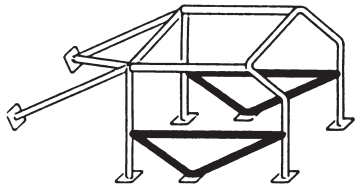

(a)

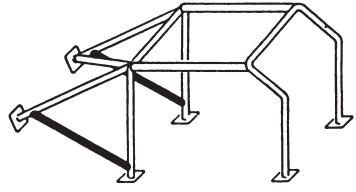

(b)

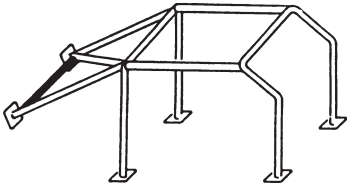

(c)

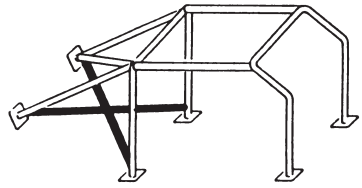

(d)

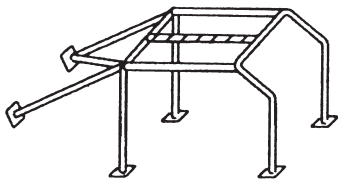

(e)

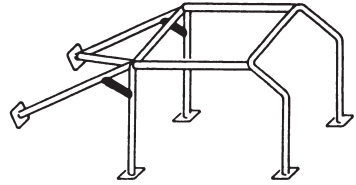

(f)

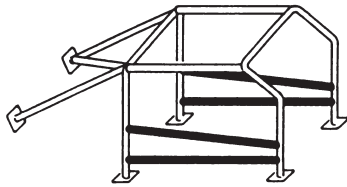

(g)

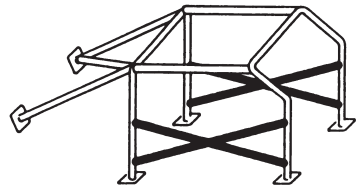

(h)

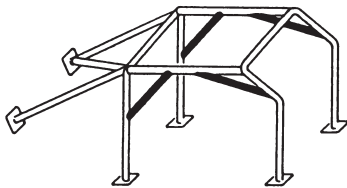

(i)

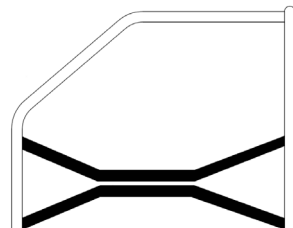

(j)

Drawing No. 12 Optional Reinforcing Members [6]

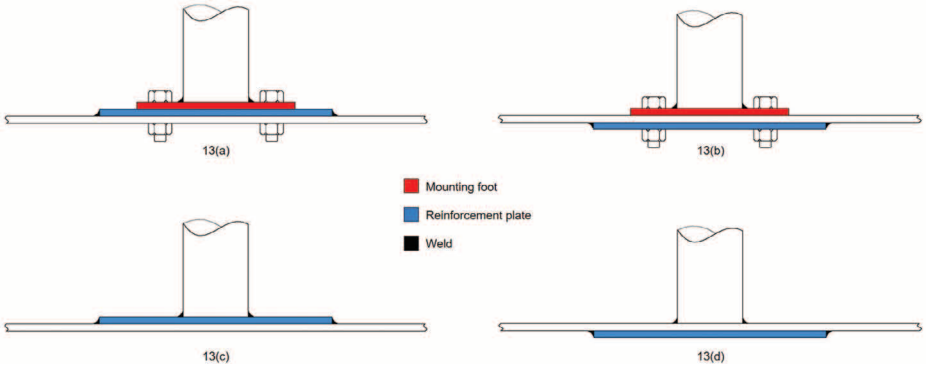

Drawing No. 13

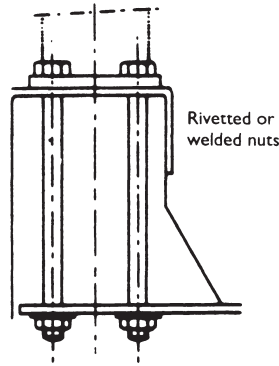

Drawing No. 14

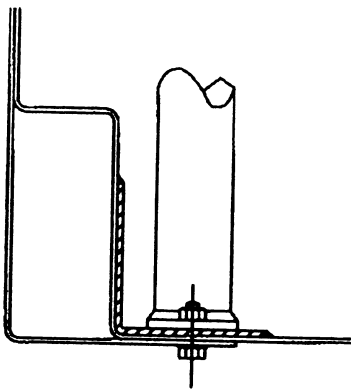

Drawing No. 15

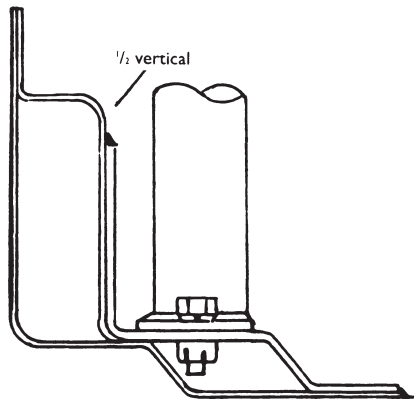

Drawing No. 16

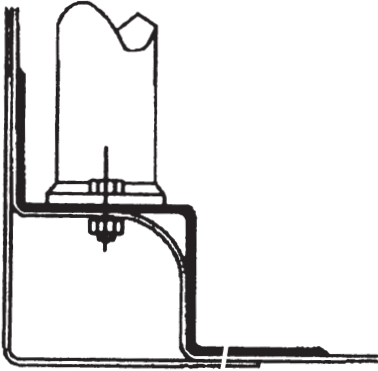

Drawing No. 17

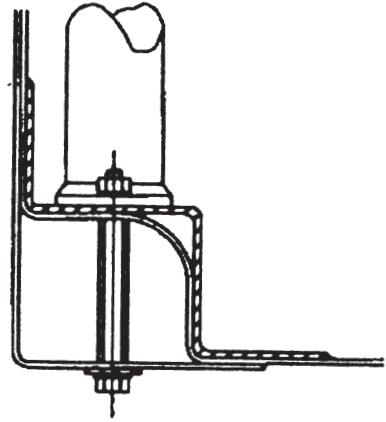

Drawing No. 18

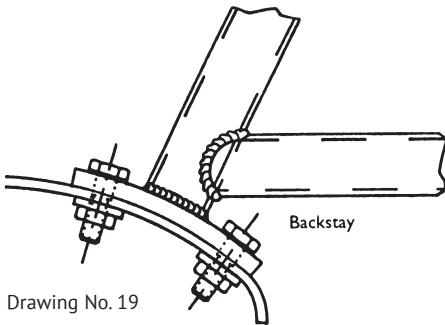

Drawing No. 19

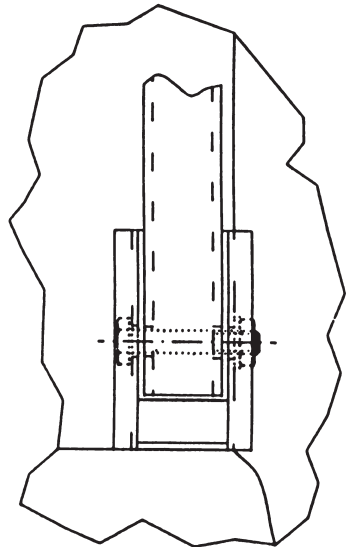
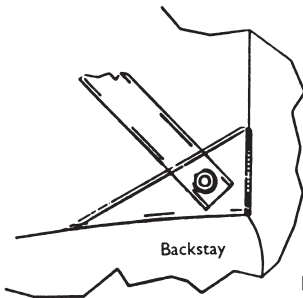

Drawing No. 20

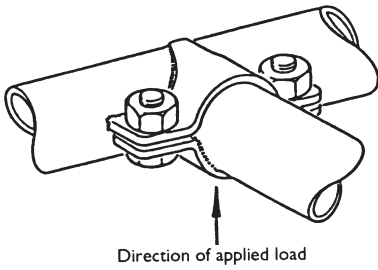

Drawing No. 21

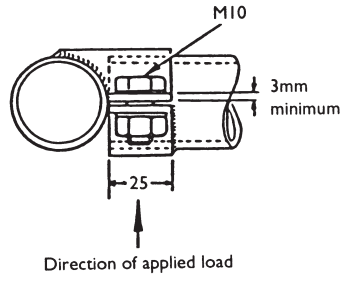

Drawing No. 22

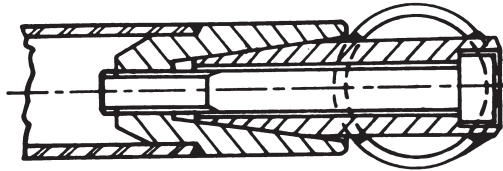

Drawing No. 23

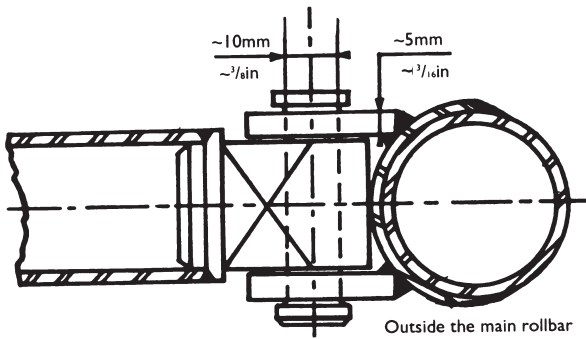

Drawing No. 24

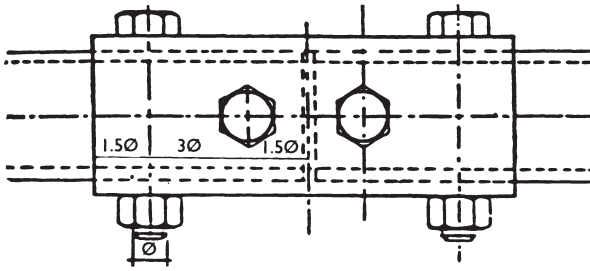

Ø = 14mm (tube ≥ 40mm < 50mm diam. ext.)
 16mm (tube ≥ 50mm diam. ext.)

Drawing No. 25

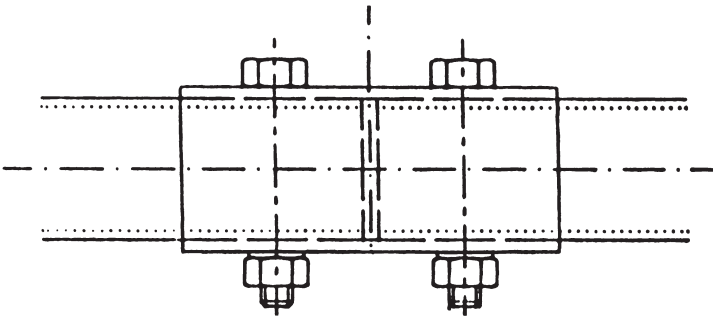

Drawing No. 26

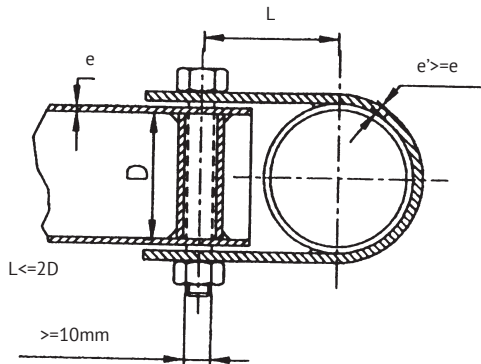

L must be minimum
 The clamp width must
 be at least 25mm

Drawing No. 27

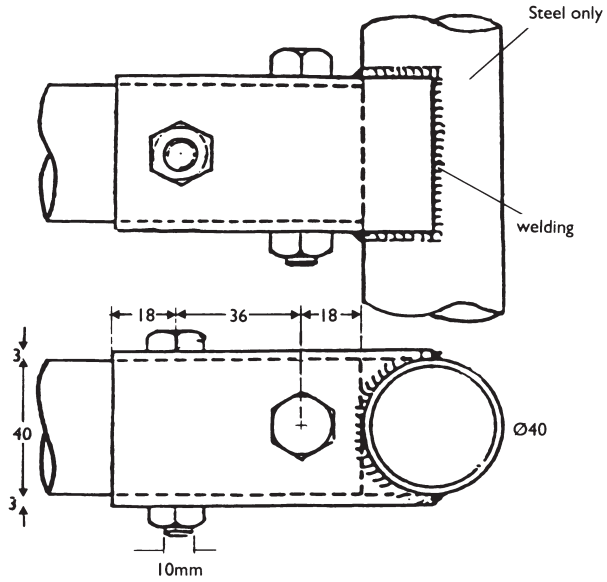

Drawing No. 28

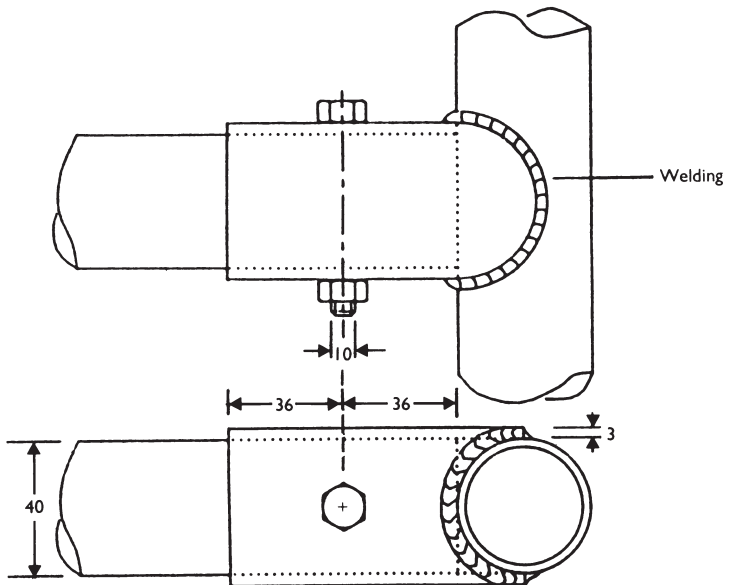

Drawing No. 29

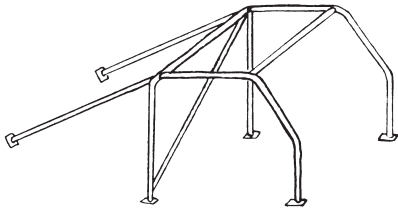

Drawing No. 6(a)

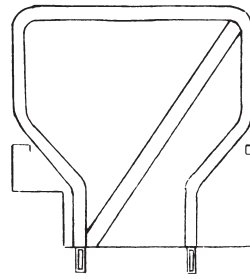

Drawing No. 38

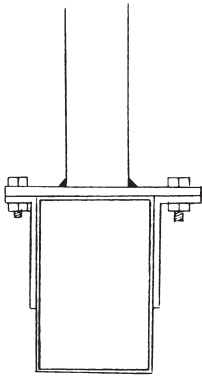

Drawing No. 33

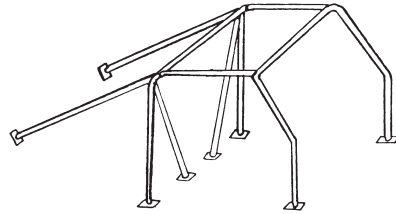

Drawing No. 34

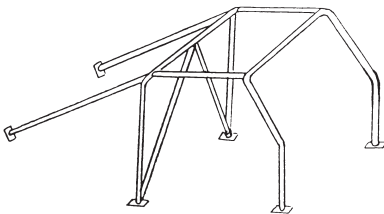

Drawing No. 35

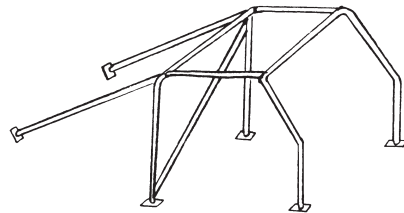

Drawing No. 36

a) Diagonal(s) across Main Hoop

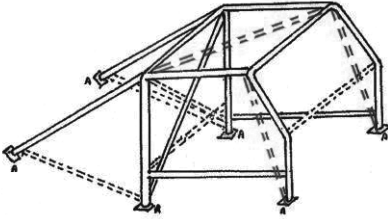

b) Diagonal(s) across Back Stays

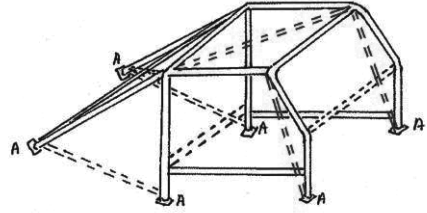

————— Mandatory minimum requirement

----- Maximum options permitted

A Mandatory mounting points

Additionally a further 8 points may be attached to the bodyshell.

Competitors should note that an installation to this drawing may contravene FIA Appendix K regulations.

Doorbars may alternatively be as shown in figure 12(g) or (h).

Roof Reinforcement may alternatively be as shown in figure 10(a) to 10(d).

Drawing No. 37

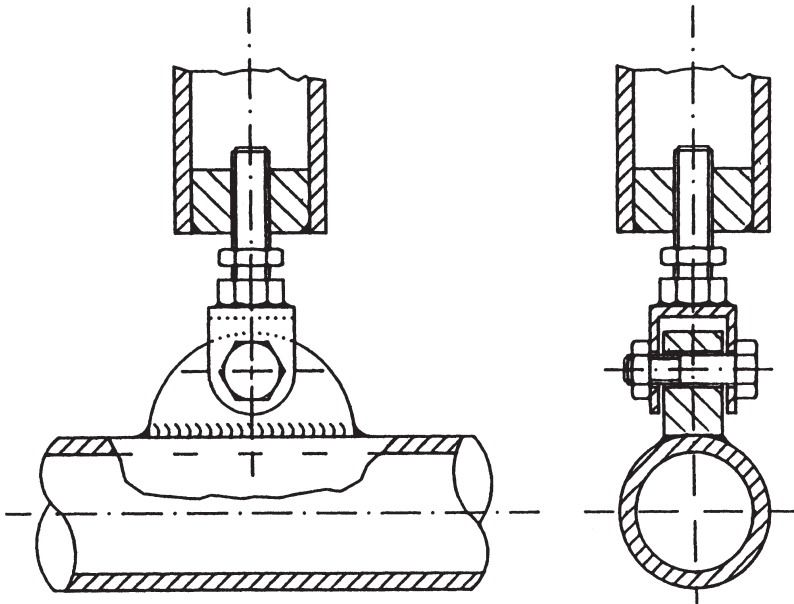

Drawing No. 30

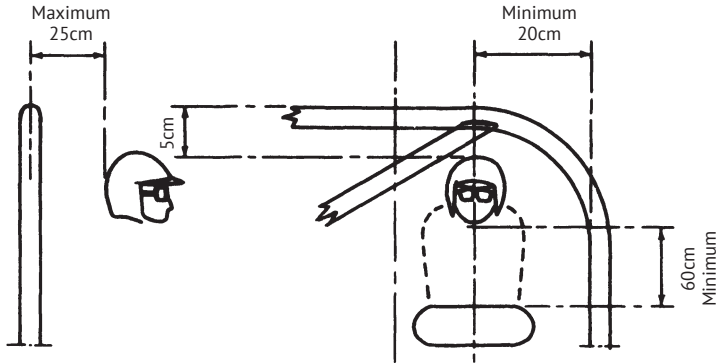

Drawing No. 31

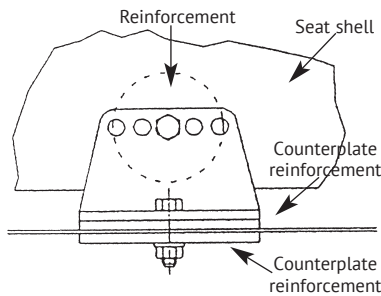

Drawing No. 32

Typical Safety Belt Installation

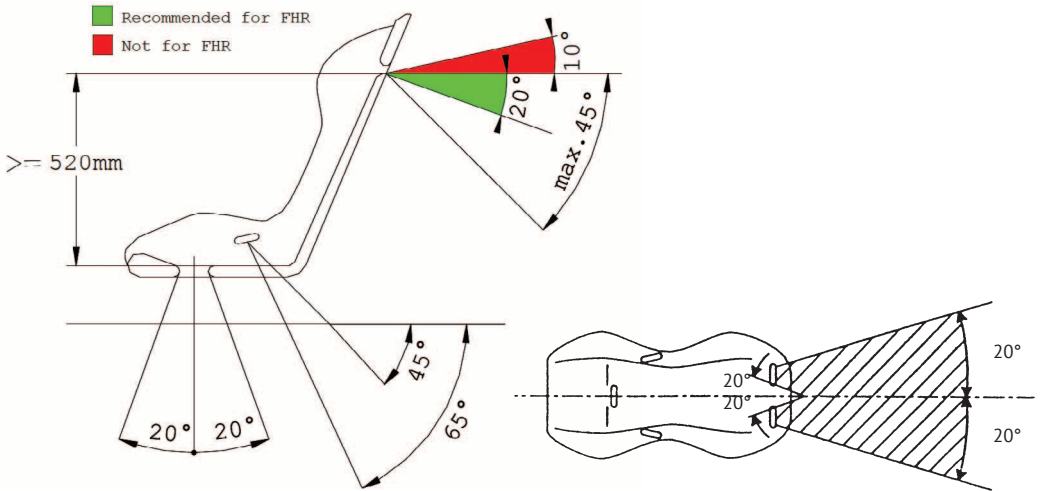

Drawing No. 39

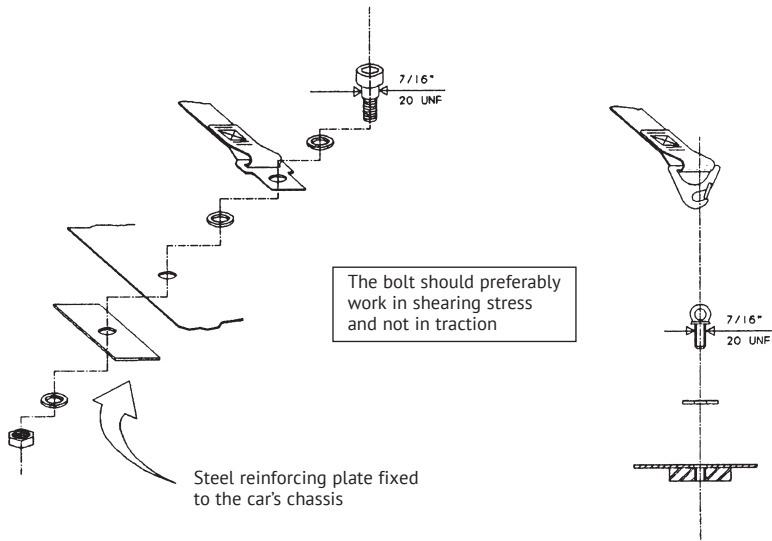

Drawing No. 40

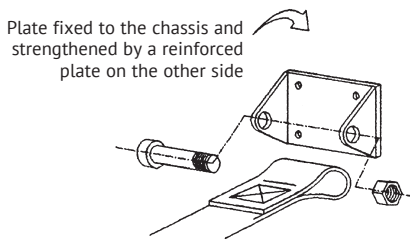

Drawing No. 41

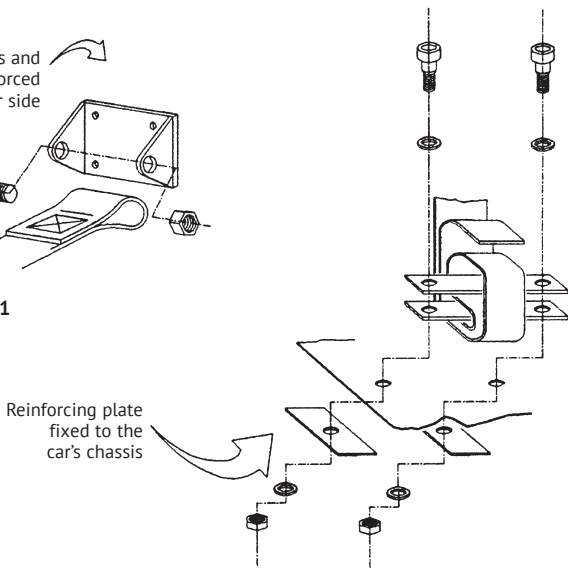

Drawing No. 42

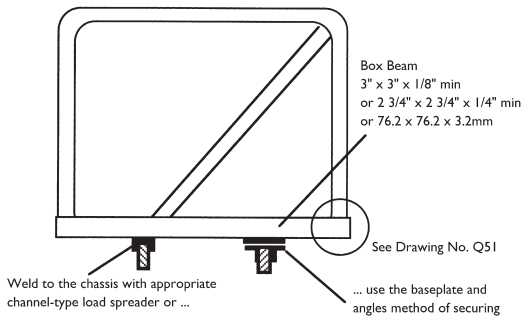

Drawing No. 50

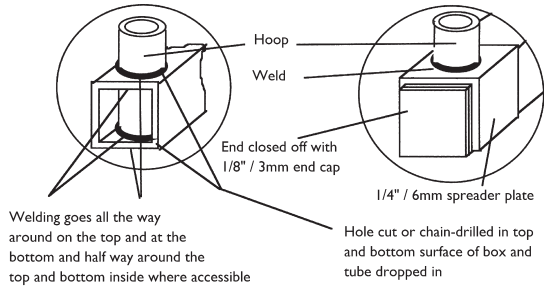

Drawing No. 51

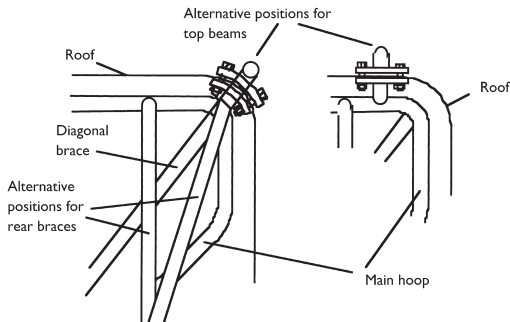

Drawing No. 52

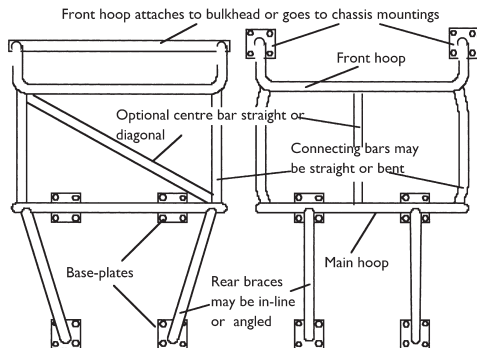

Drawing No. 53

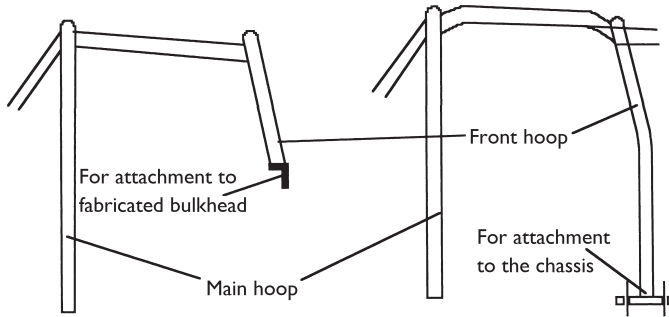

Drawing No. 54

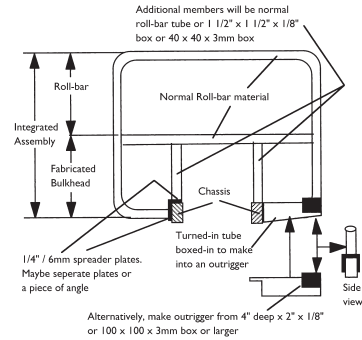

Drawing No. 55

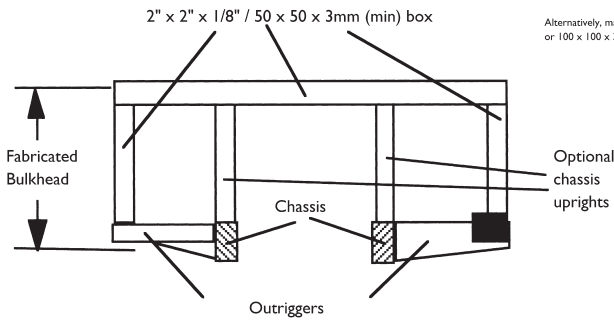

Drawing No. 56

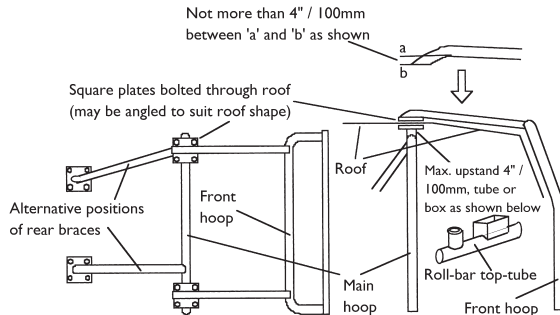

Drawing No. 57

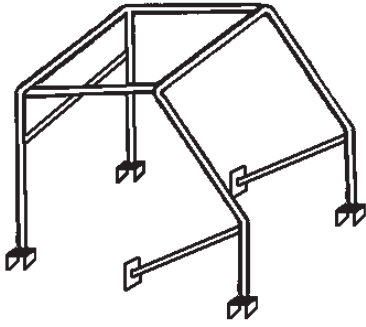

Drawing No. 58

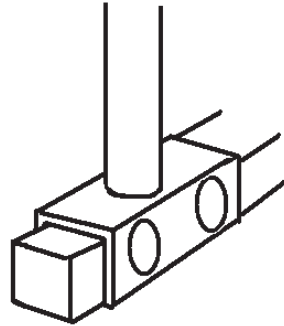

Drawing No. 59

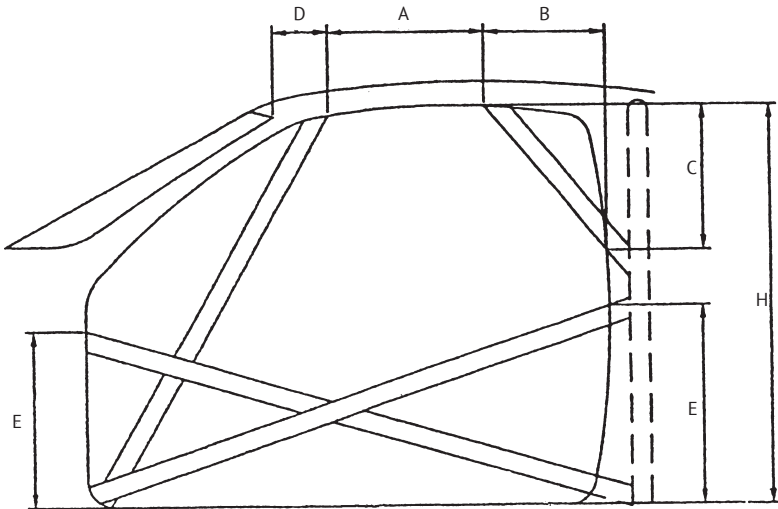

Drawing No. 43

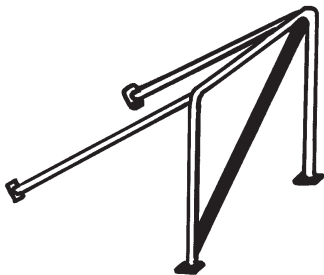

Drawing No. 60(i)

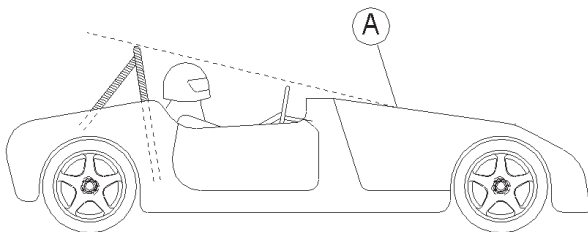

'A' is the substantial structure forward of the driver such as to act as the front rollbar. No part of the driver's helmet is to pass through a line struck from the top of the rollbar to this structure.

Drawing No. 60(ii)

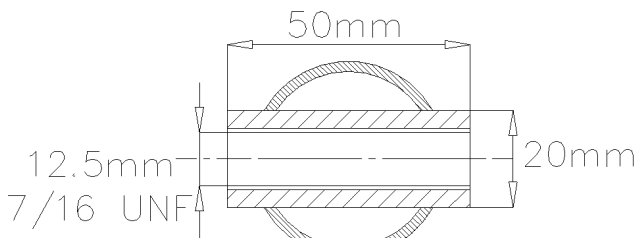

Drawing No. 44

"U" shape extruded section

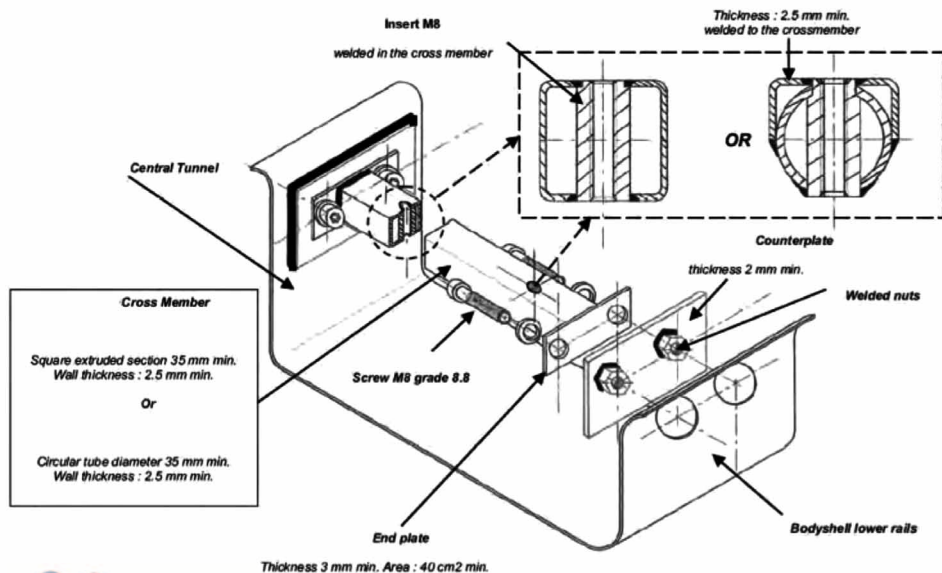

Drawing No. 64(a)

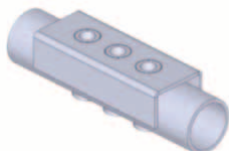

Drawing No. 64(b)

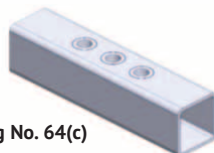

Drawing No. 64(c)

Drawing number 61

Dimension B Height over front seats (measured between 0° and 15° towards the rear in relation to the vehicle using the test seat weight)

Dimension C Width for the front seats

Dimension D Height over the rear seats (measured as Dimension B)

Dimension E Width of rear seats.

Dimension F Distance from the centre of the hub of the steering wheel to the brake pedal (if the steering wheel is adjustable it must be placed in the median position).

Dimension G Length from the centre of the hub of the steering wheel to the bulkhead of the rear seat, or if possible to the rear face of the rear seat (maximum tilt 15°) If the steering wheel is adjustable it must be placed in the median position.

B and D are measured between the bottom of the seat compressed by the test seat weight, the axis of which is vertical, and the ceiling (padding compressed). If the seats are separate, the measurement is taken in the middle of each of the seats. In the case of longitudinally adjustable seats, the seats will be placed in the median position. If there is a bench seat in the front, the measurement is taken at 25cm from the centreline of the car.

C and E are the maximum widths measured along the vertical plane passing through the axis of the standard test seat weights placed on the seats, being able to be freely maintained over a height of at least 25cm and a length of at least 40cm. The minimum dimensions (in cm) according to the cylinder capacity (in cm³) are the following, with $H = F + G$

Internal Dimensions

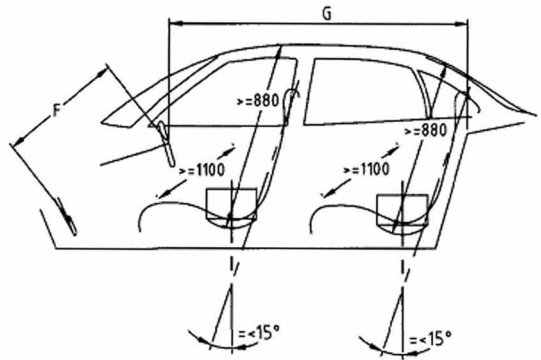

Drawing 202/203

<i>Engine Capacity</i>	<i>Dim. B</i>	<i>Dim. C</i>	<i>Dim. D</i>	<i>Dim. E</i>	<i>Dim. H</i>
From 0 to 1,300	Free	90	Free	90	180
From 1,300 to 2,000	88	110	88	110	200
Over 2,000	93	120	93	120	210

Drawing number 62

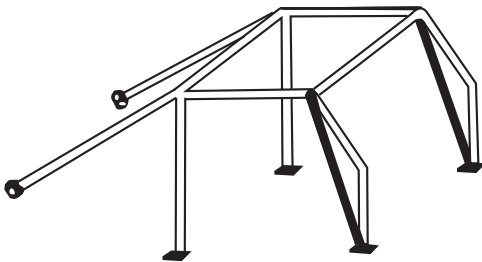

Drawing number 63

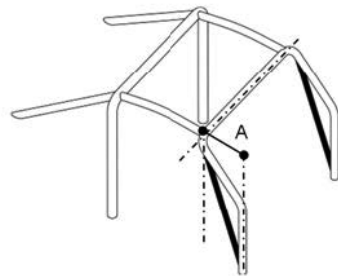

Drawing number 65

